

REVISION TABLE					
REV	ECN#	DESCRIPTION	REV BY	APPROVED	DATE
---	---	Original Drawing	OOG	MPW	8-1-10

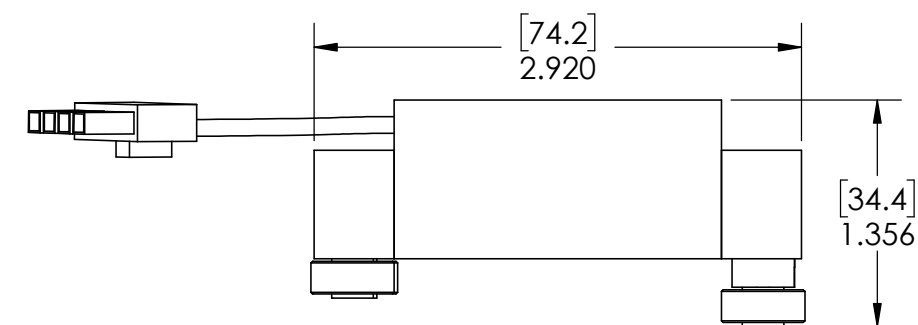
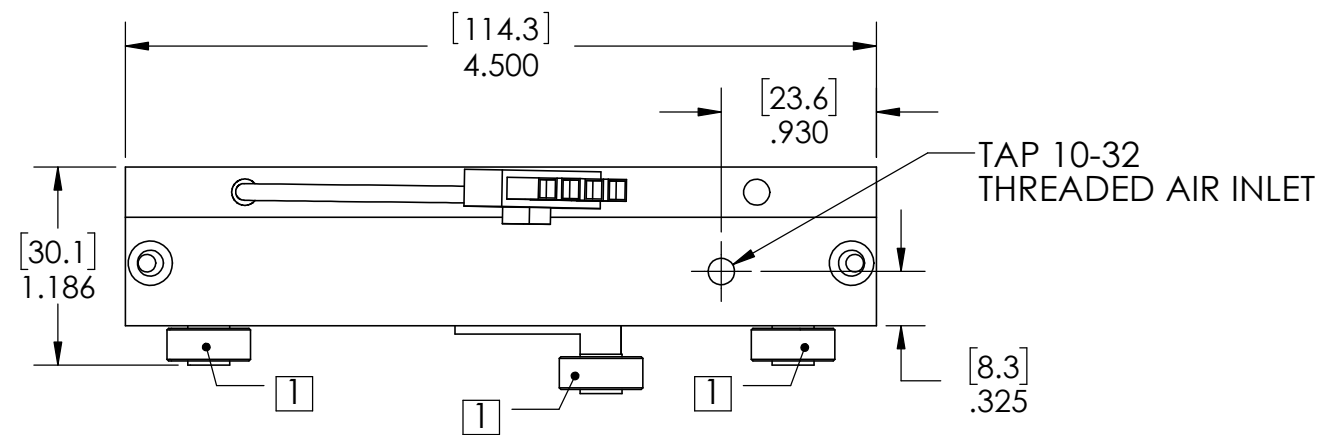
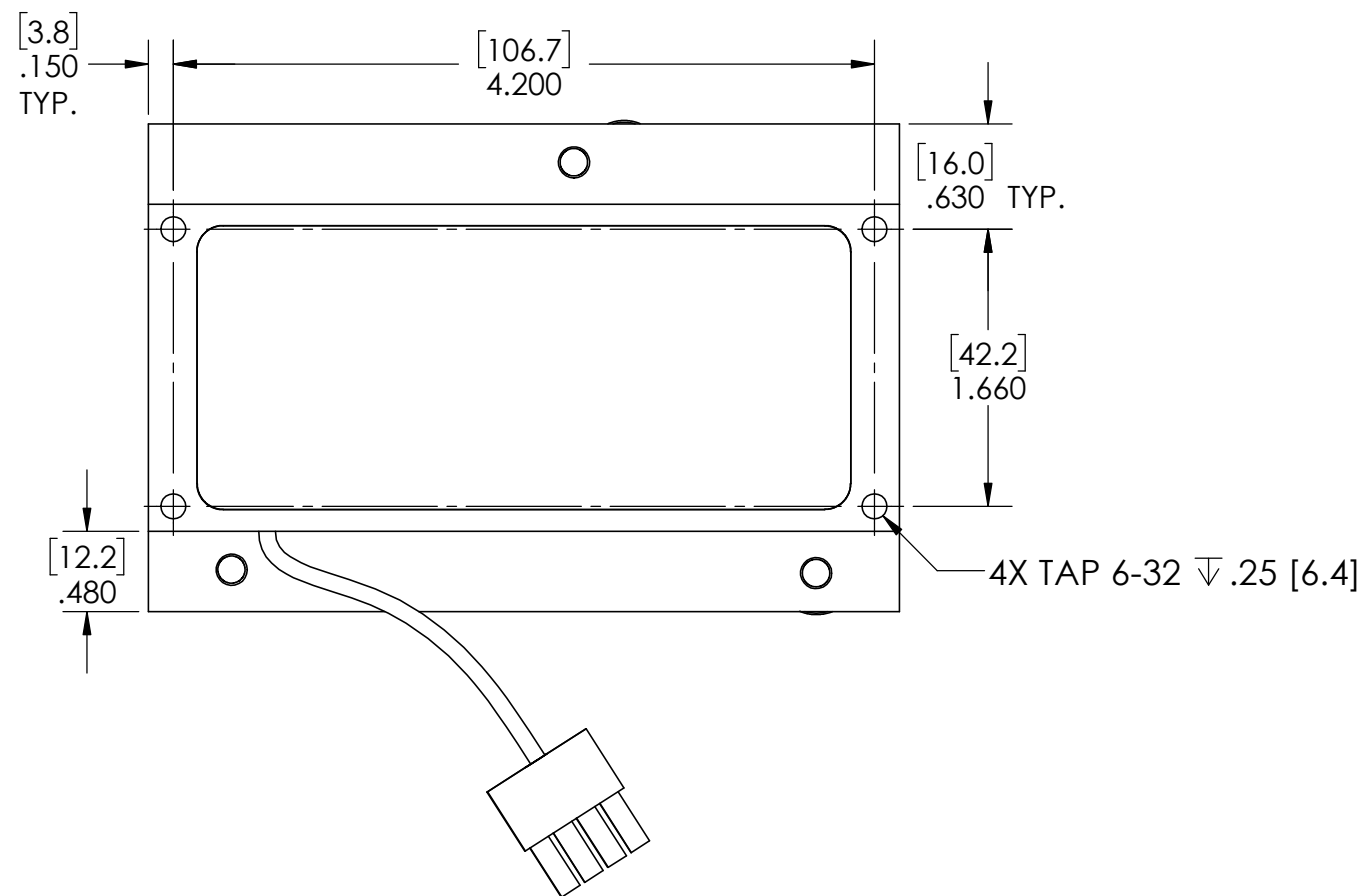

H2W Technologies, Inc.
 Santa Clarita, CA 91350 USA
 Tel: (661) 291-1620
www.h2wtech.com

These drawings and specifications are the property of H2W Technologies, Inc. They are issued in confidence and shall not be reproduced, copied, or used without written permission from H2W Technologies, Inc.

UNLESS SPECIFIED OTHERWISE:
 All dimensions are in inches
 Standard Tolerances are as follows
 .XXX ±.005 ANGLES ±.1°
 .XX ±.010 FILLETS .010
 .X ±.020 CORNERS .010
 Remove All Burrs and Sharp Edges

**FOR
 REFERENCE
 ONLY**

MATERIAL

FINISH

TITLE

Single Axis Stepper Model #:
STS-1220-AP4T

DWG # **10-0528**

REV **----**

DATE **8-1-10** SHEET **1 of 4**

COMPATIBLE PLATEN SPECIFICATIONS

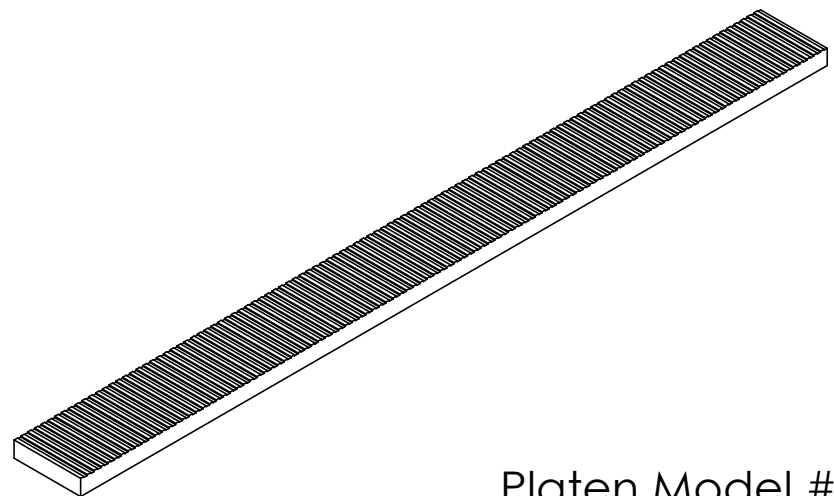
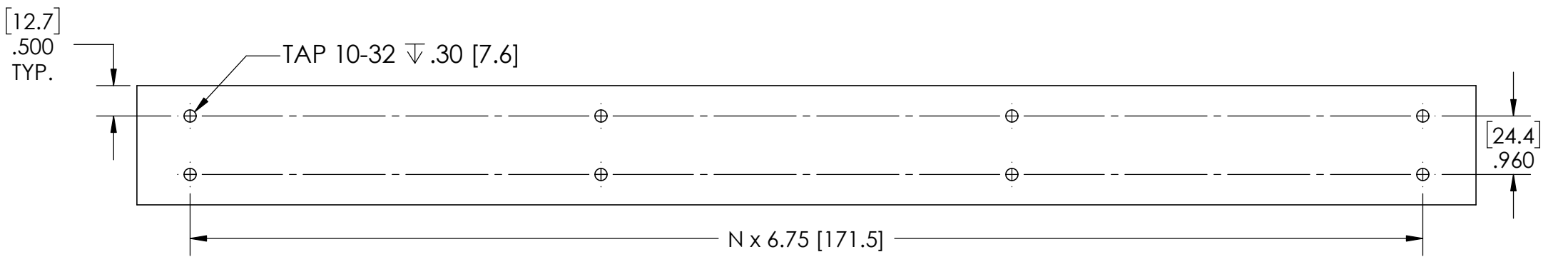
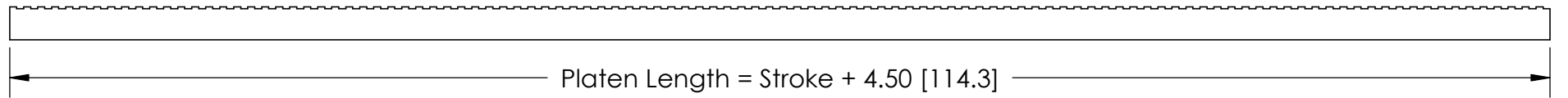
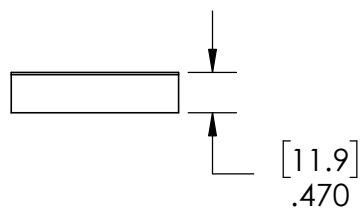
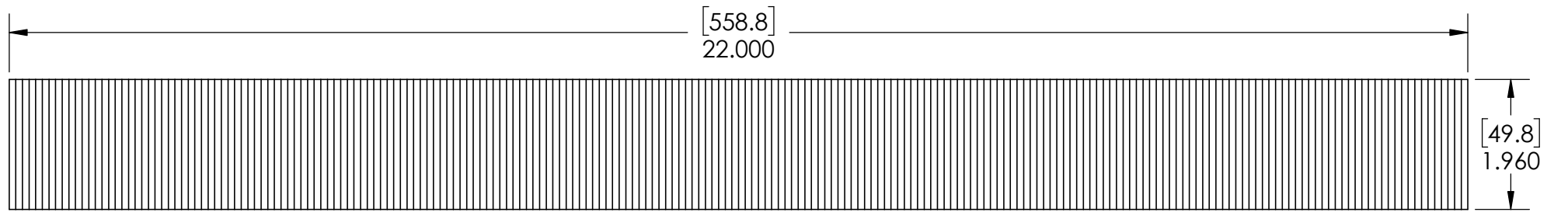

Platen Model #: STP-20-XXX-A

MOTOR SHOWN MOUNTED ON PLATEN

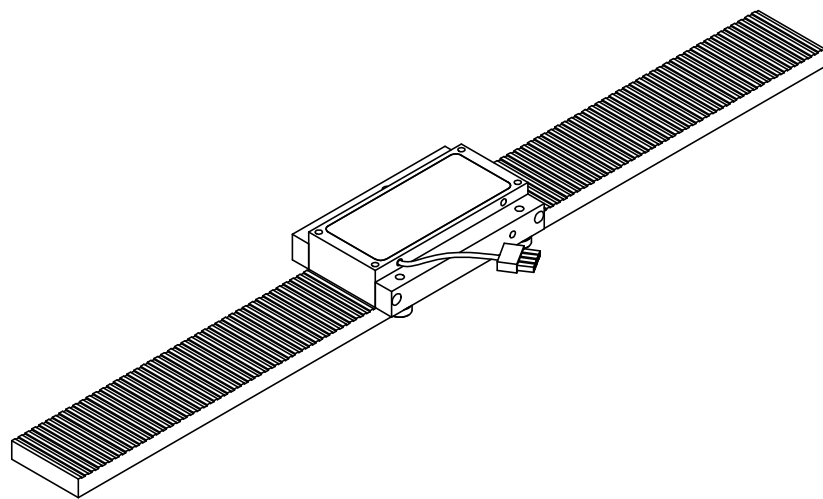
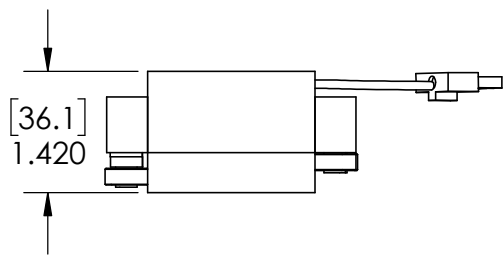
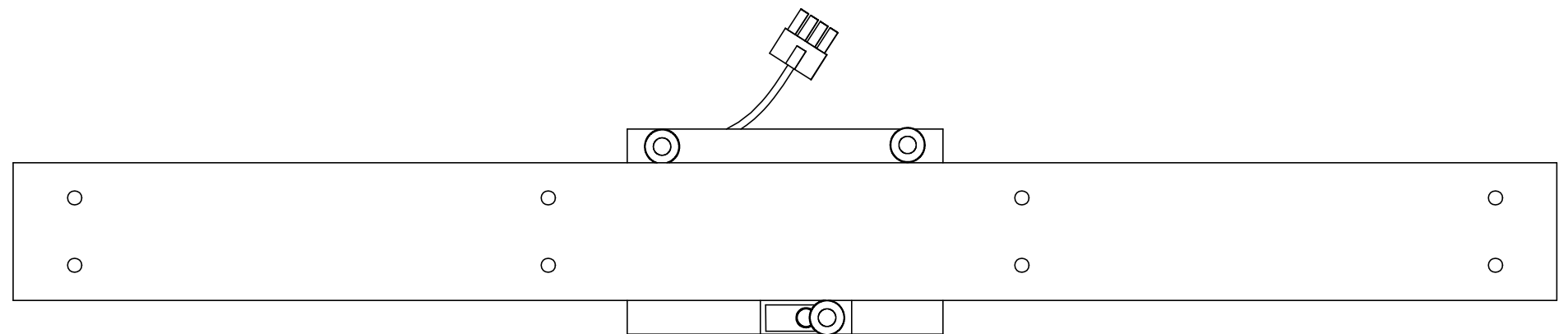
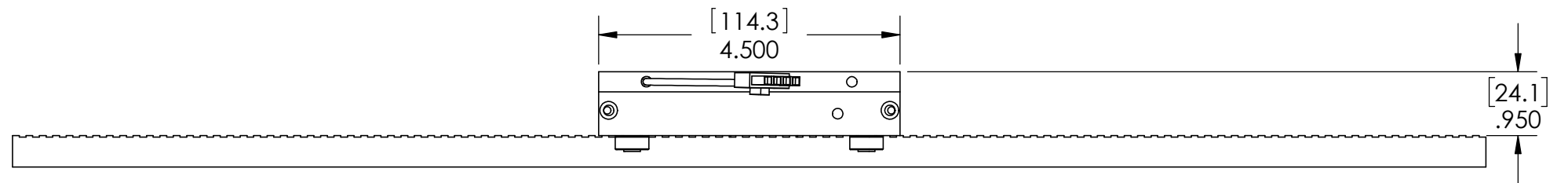
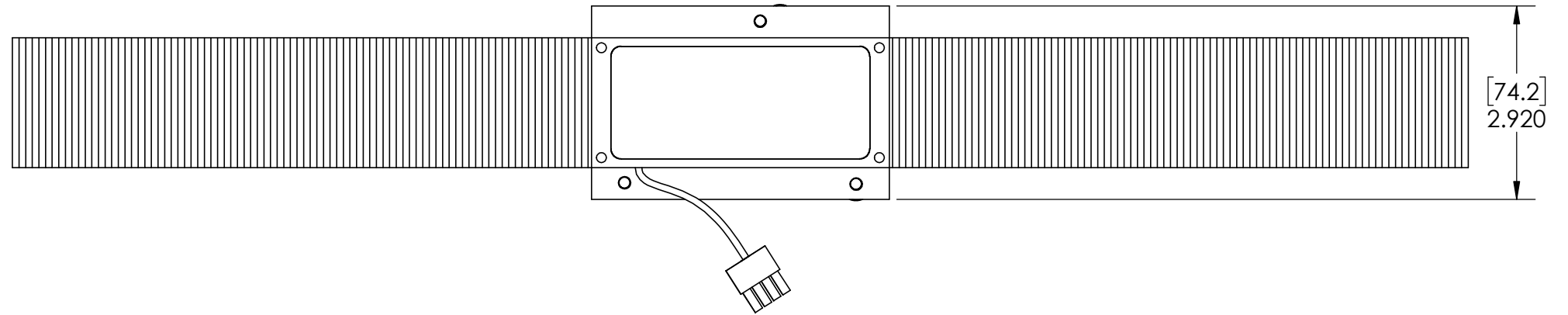

H2W Technologies, Inc.
 Santa Clarita, CA 91350 USA
 Tel: (661) 291-1620
www.h2wtech.com

These drawings and specifications are the property of H2W Technologies, Inc. They are issued in confidence and shall not be reproduced, copied, or used without written permission from H2W Technologies, Inc.

UNLESS SPECIFIED OTHERWISE:
 All dimensions are in inches
 Standard Tolerances are as follows
 .XXX ±.005 ANGLES ±.1°
 .XX ±.010 FILLETS .010
 .X ±.020 CORNERS .010
 Remove All Burrs and Sharp Edges

**FOR
 REFERENCE
 ONLY**

MATERIAL	
FINISH	

TITLE	Single Axis Stepper Model #: STS-1220-AP4T
-------	--

DWG #	10-0528
REV	----
DATE	8-1-10
SHEET	3 of 4

1

2

3

4

5

LINEAR STEPPER MOTOR SPECIFICATIONS

Motor P/N	STS-1220-AP4T	
Continuous Force	12.0 LBS	53.1 N
Rated Current/Phase	3.75 Amp	
Resistance/Phase @ 20C	1.15 ohms	
Inductance/Phase @ 20C	1.15 mH	
Motor Phases	2	
Bearing Type	Air Bearing	
Nominal Air Pressure	60 psi	
Motor Mass	14.8 oz	419 grams

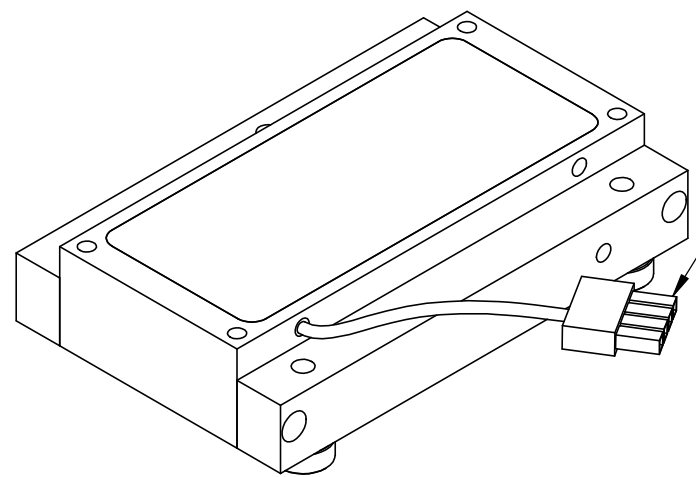

MOTOR POWER CONNECTOR
Molex P/N: 39-01-4041

Lead Color	Function
Red	A+
White	A-
Orange	B+
Green	B-

Molex P/N: 39-01-4041
CONNECTS TO
Molex P/N: 39-01-4046

LEAD WIRE LENGTH: 6.0in [152.4mm]

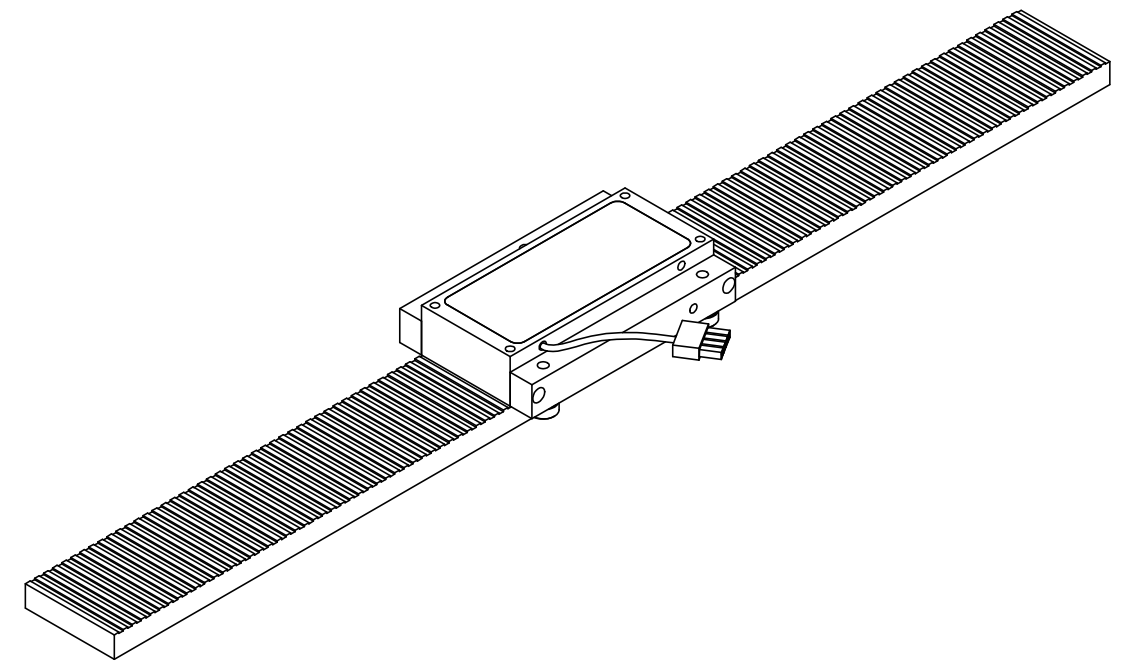

NOTES:

1 ALL BEARINGS HAVE DOUBLE TEFLON SEALS.



H2W Technologies, Inc.
Santa Clarita, CA 91350 USA
Tel: (661) 291-1620
www.h2wtech.com

These drawings and specifications are the property of H2W Technologies, Inc. They are issued in confidence and shall not be reproduced, copied, or used without written permission from H2W Technologies, Inc.

UNLESS SPECIFIED OTHERWISE:
All dimensions are in inches
Standard Tolerances are as follows
.XXX ±.005 ANGLES ±.1°
.XX ±.010 FILLETS .010
.X ±.020 CORNERS .010
Remove All Burrs and Sharp Edges

**FOR
REFERENCE
ONLY**

MATERIAL	
FINISH	

TITLE	Single Axis Stepper Model #: STS-1220-AP4T
-------	--

DWG #	10-0528
REV	----
DATE	8-1-10
SHEET	4 of 4