

1

2

3

4

5

REVISION TABLE					
REV	ECN#	DESCRIPTION	REV BY	APPROVED	DATE
---	---	Original Drawing	SDC	MPW	06-22-15
A	1733	Changed motor cover, motor directions, and connections	OOG	MPW	12-1-15

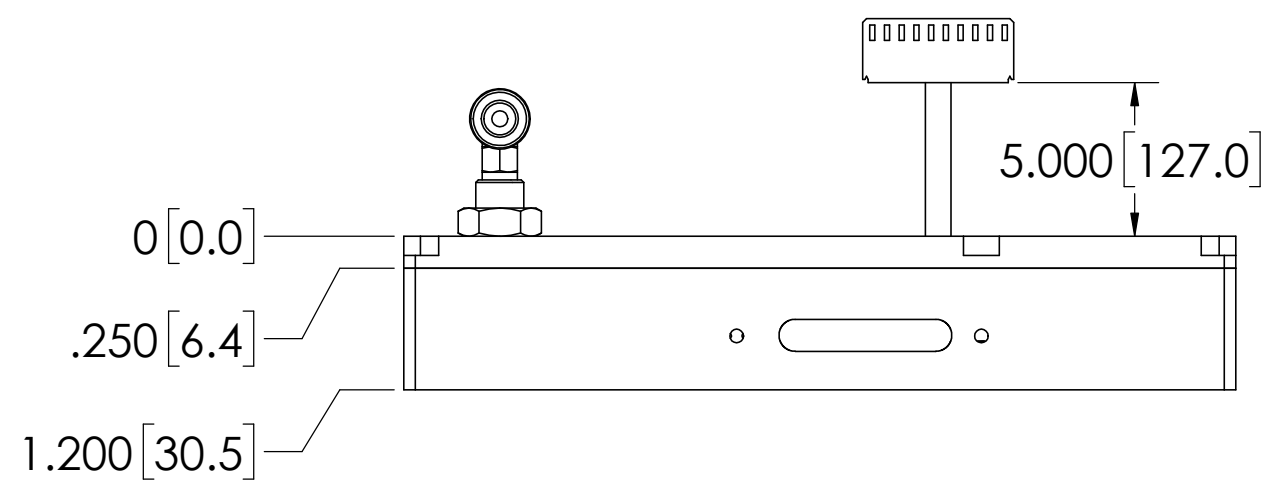
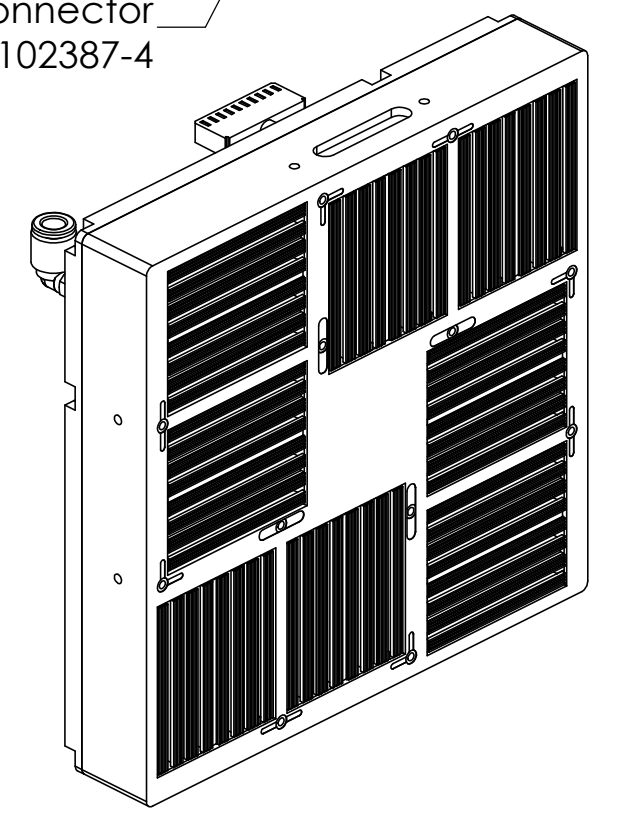
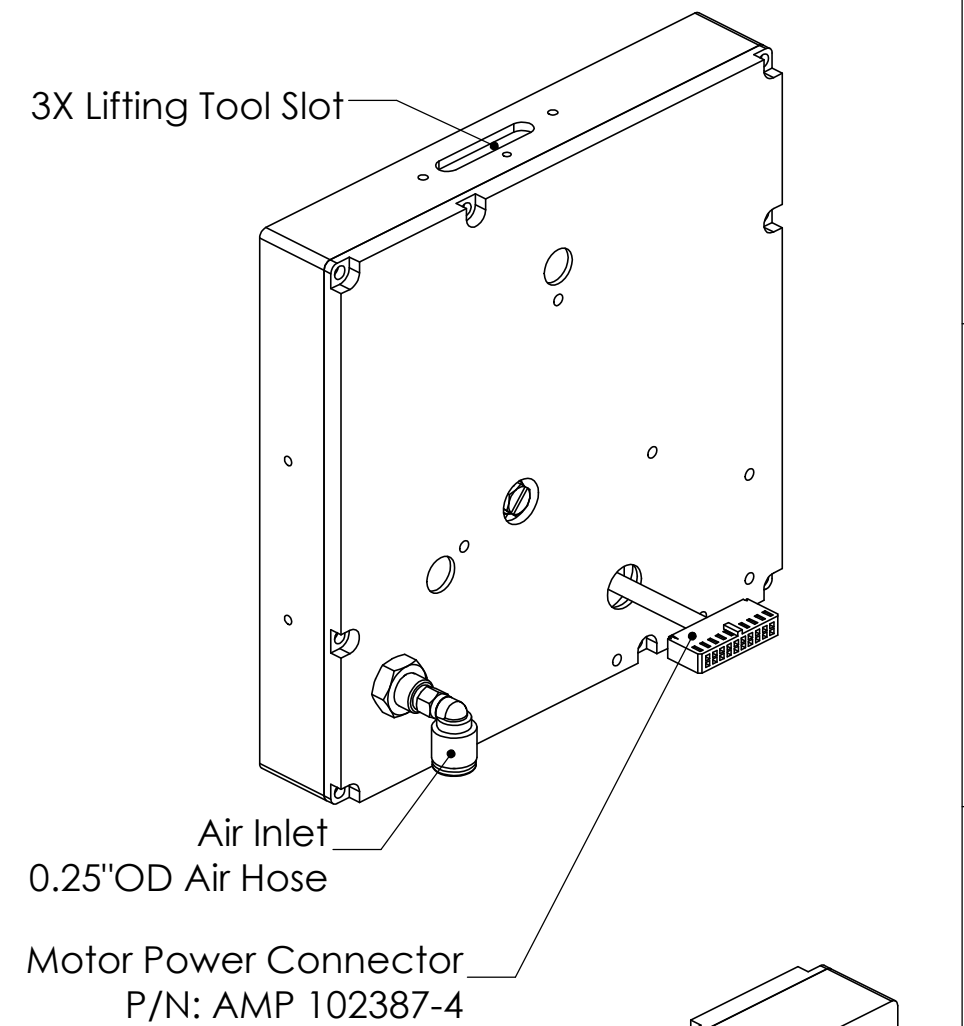
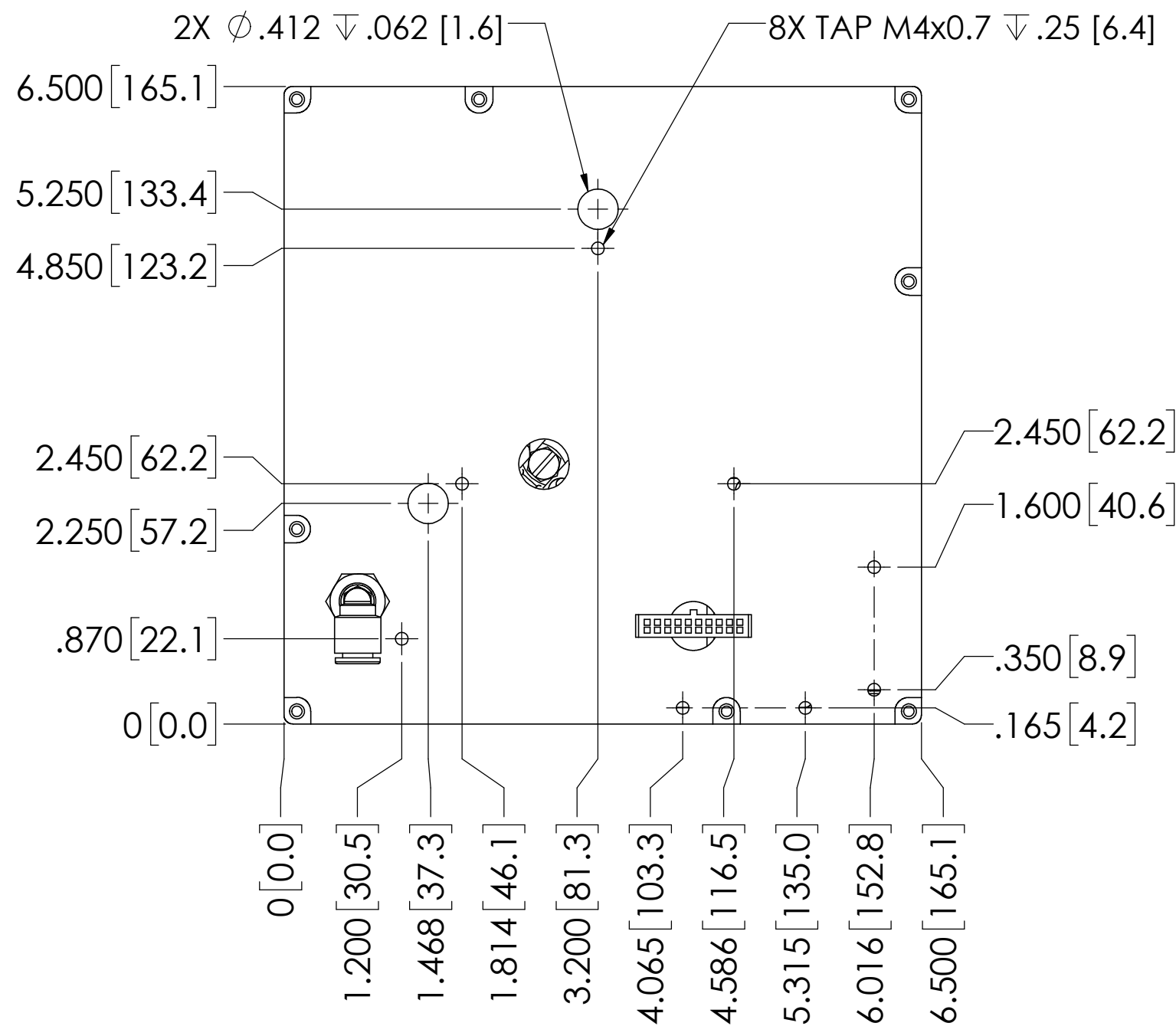

Motor Specifications LMDS2004-2A1B		
General		
Static Force	lbs [N]	24.5 [110]
Force @ 40 in/sec	lbs [N]	10.8 [48]
Amps/Phase	Amps	4
Continuous Power	Watts	53
Electrical		
Resistance	Ohms	3.2
Inductance	mH	3.3
Electrical Time Constant	msec	0.97
Mechanical		
Bearing Type	Air	
Nominal Air Pressure	60 psi	
Airflow	CFM [L/min]	3.5 [98]
Attractive Force	lbs [N]	324 [1441]
Forcer Mass	lbs [kg]	4.5 [2.0]

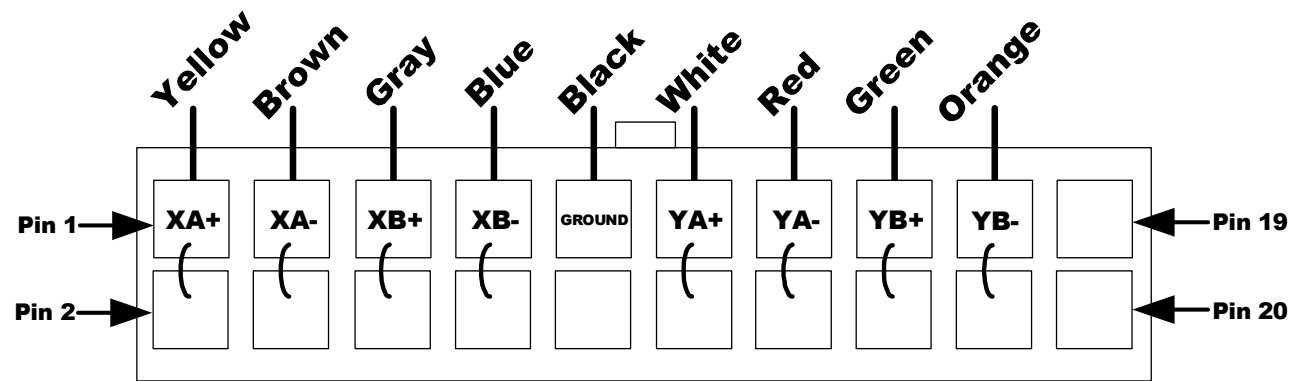
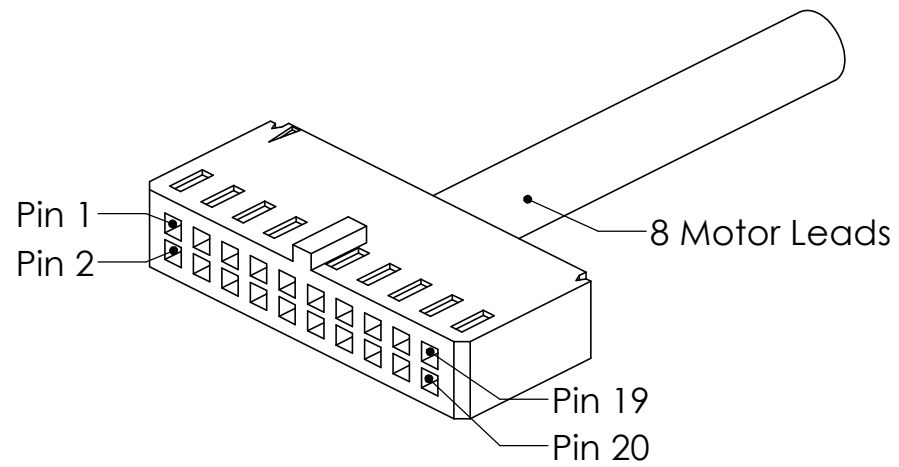
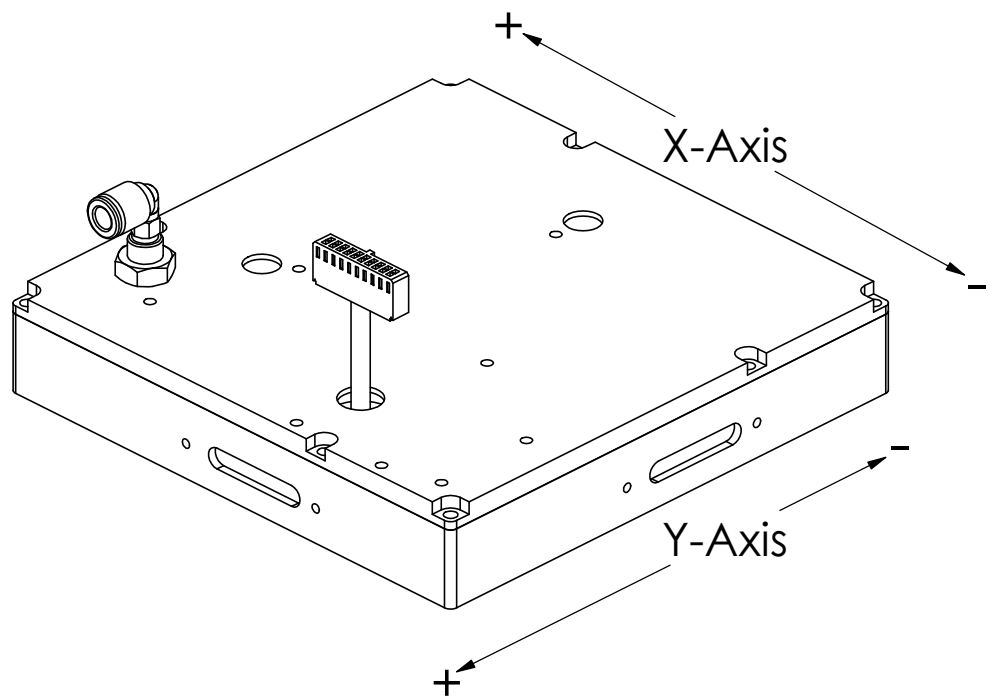

Note: 8 Motor Leads are jumpered to adjacent pin on connector