

1

2

3

4

5

STAGE SHOWN AT MIDSTROKE

REVISION TABLE					
REV	ECN#	DESCRIPTION	REV BY	APPROVED	DATE
--	--	Original Drawing	OOG	MPW	1-25-15

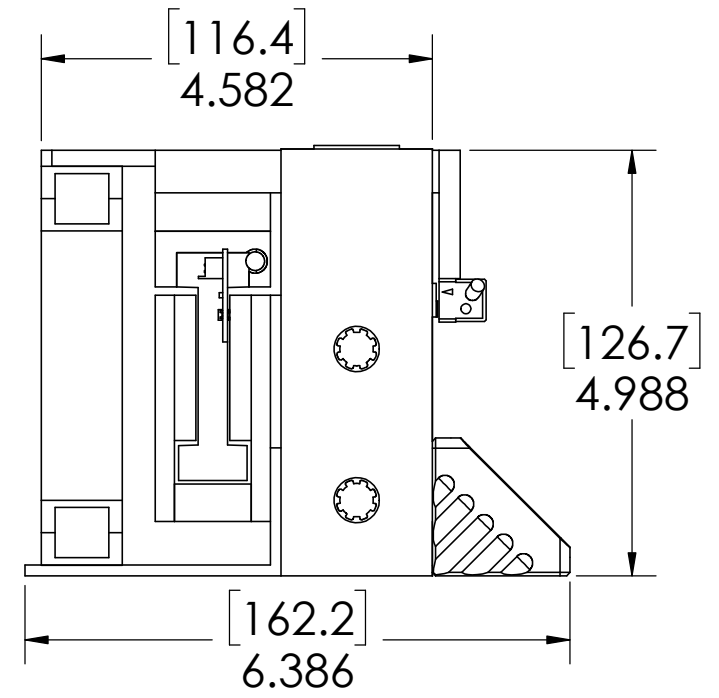
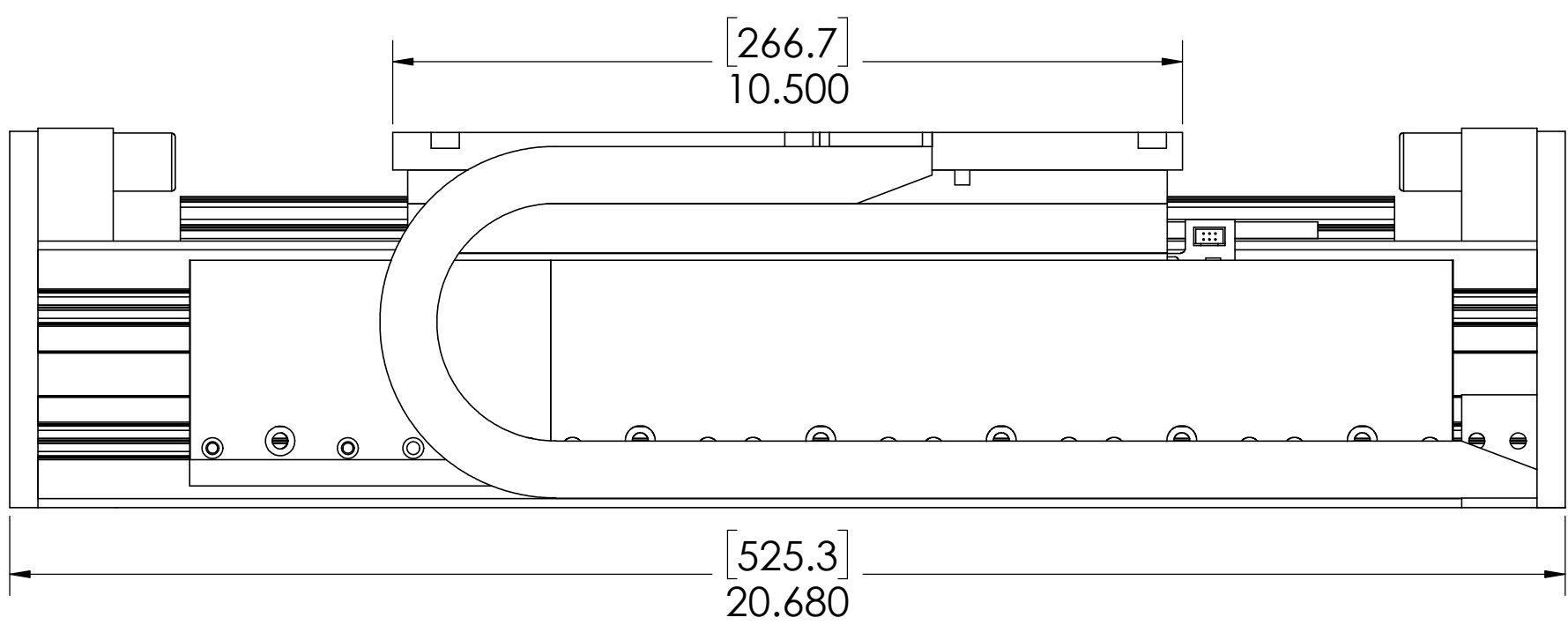
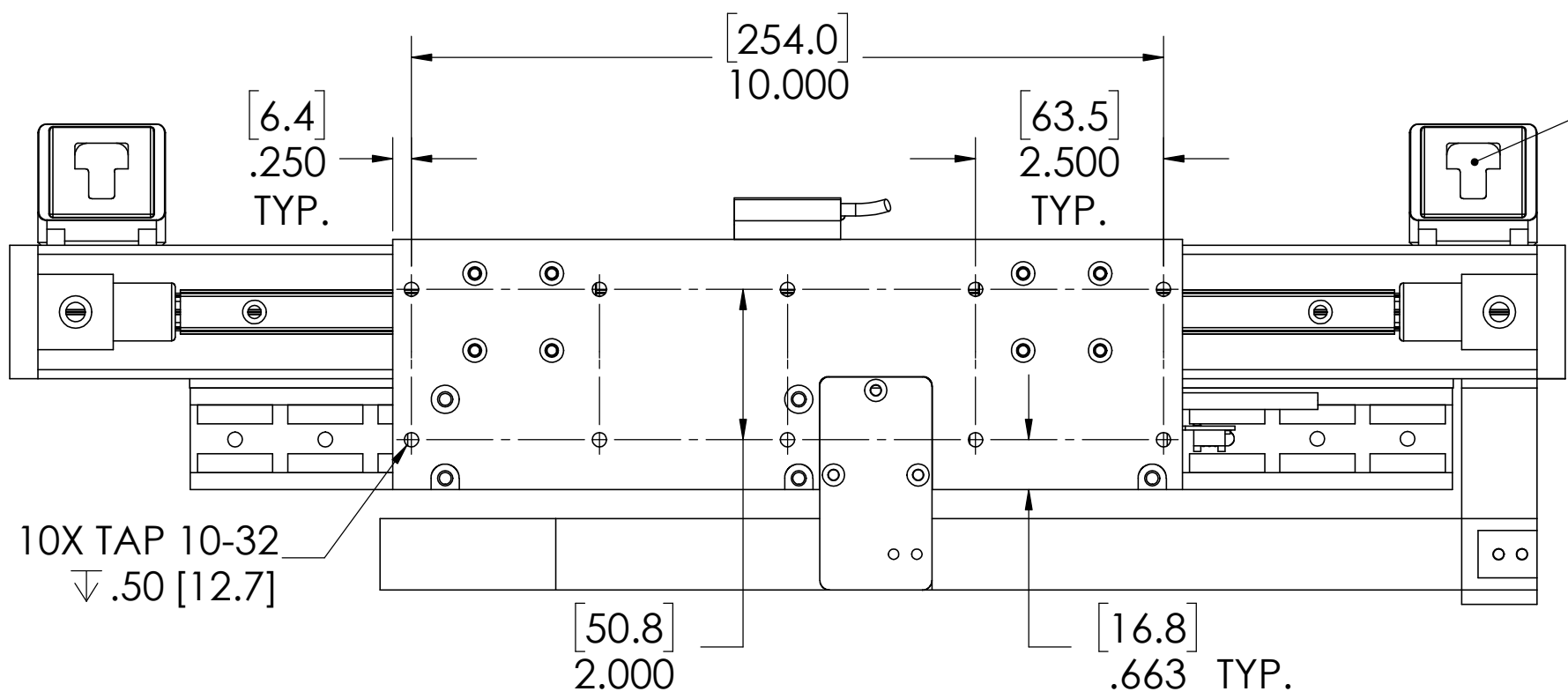

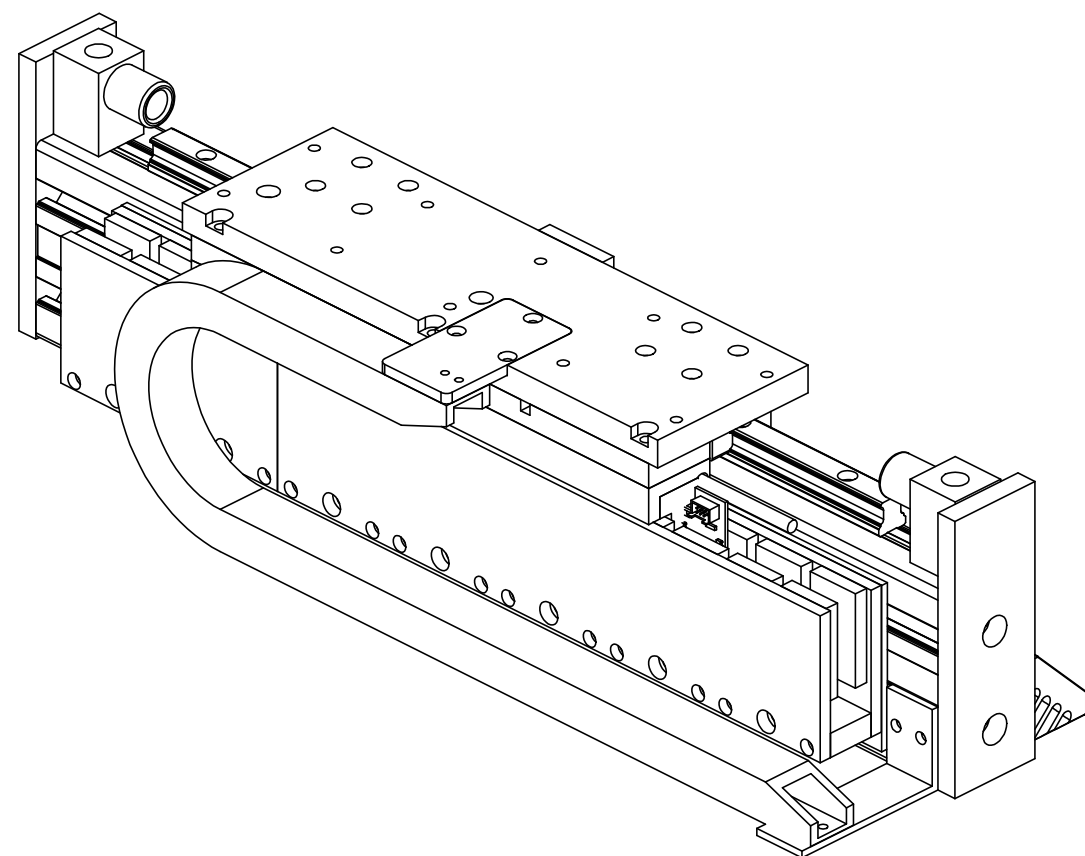
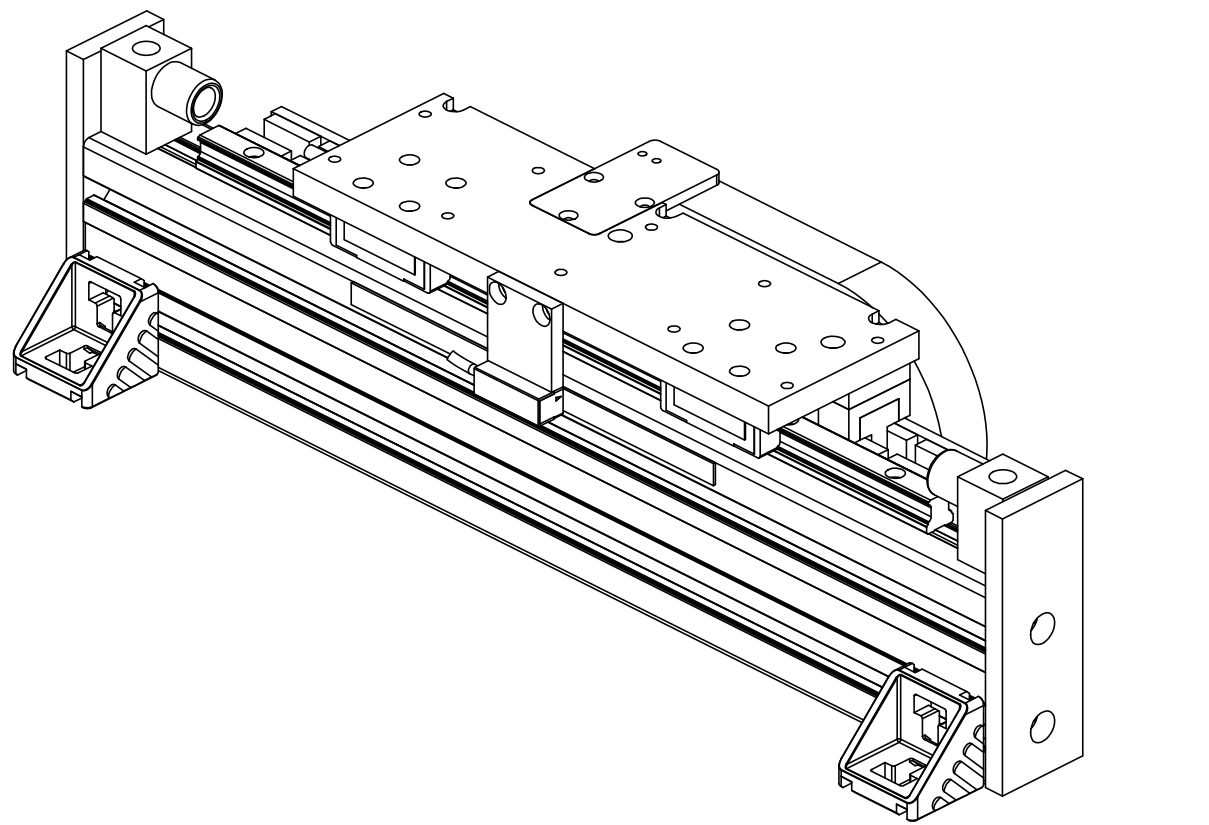

SINGLE RAIL POSITIONING STAGE SPECIFICATIONS		
Motor P/N	BLDM-D08	
Stroke	5.75 in	146 mm
Encoder Resolution	1 micron	
Bearing Type	Recirculating Ball	
Moving Mass	6.0 lbs	2.70 kg
Total Mass	24 lbs	10.7 kg
Resistance @ 20C	36.4 ohms	
Inductance @ 20C	48.3 mH	
Electrical Time Constant	1.3 msec	
Motor Constant	3.7 LBS/SQRT(Watt)	16.4 N/SQRT(Watt)
Force Constant	22.3 LBS/Amp	99.3 N/Amp
Back EMF	2.52 V/ips	99.3 V/m/sec
Force @ 100% Duty	33 lbs	147 N
Power @ 100% Duty	103.4 watts	
Current @ 100% Duty	1.5 amps	
Force @ 10% Duty	99 lbs	440 N
Power @ 10% Duty	930.6 watts	
Current @ 10% Duty	4.5 amps	
Stage Length	20.68 in	525.3 mm
Stage Width	6.37	161.8 mm
Stage Height	4.98	126.5 mm