

REVISION TABLE					
REV	ECN#	DESCRIPTION	REV BY	APPROVED	DATE
--	--	Original Drawing	OOG	MPW	3-15-17

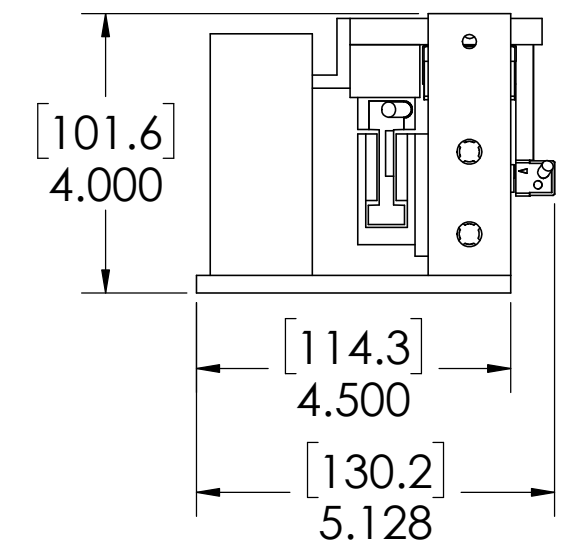

# PAYLOAD MOUNTING FEATURES

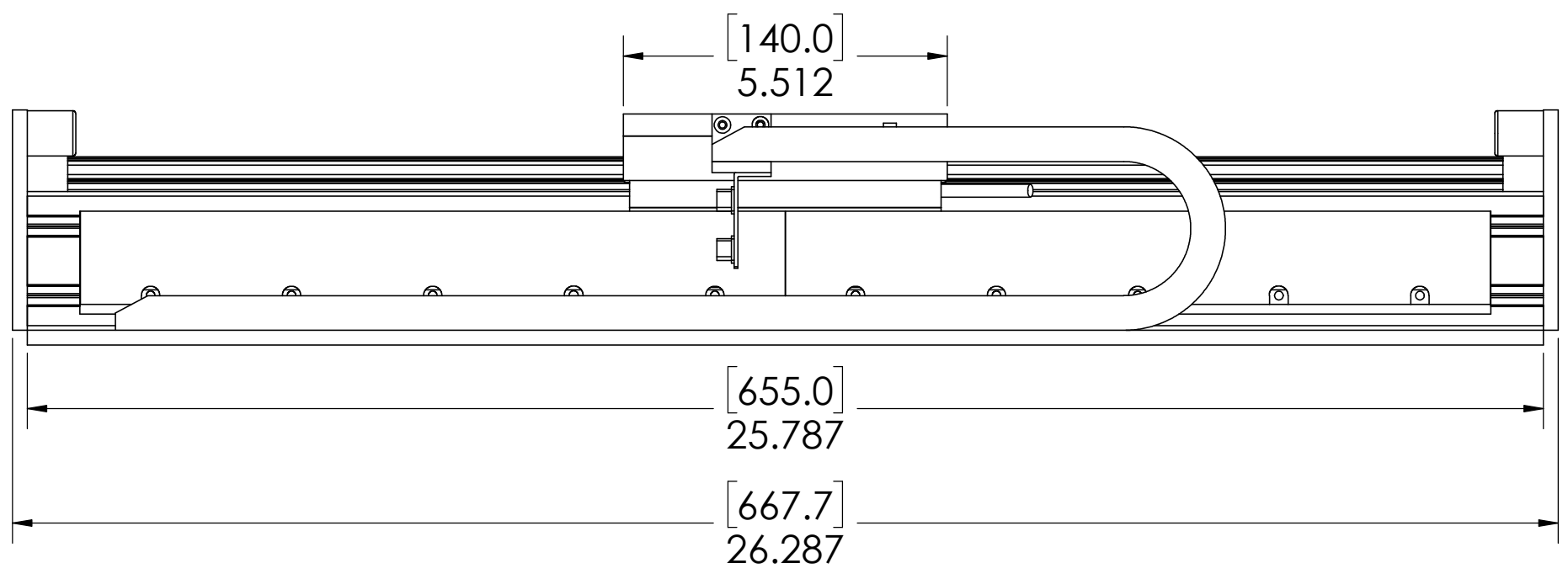
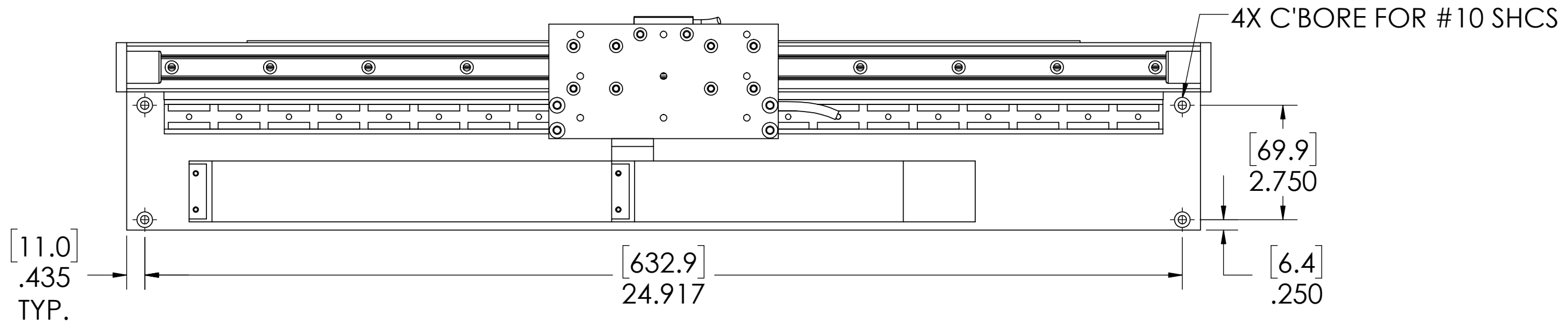
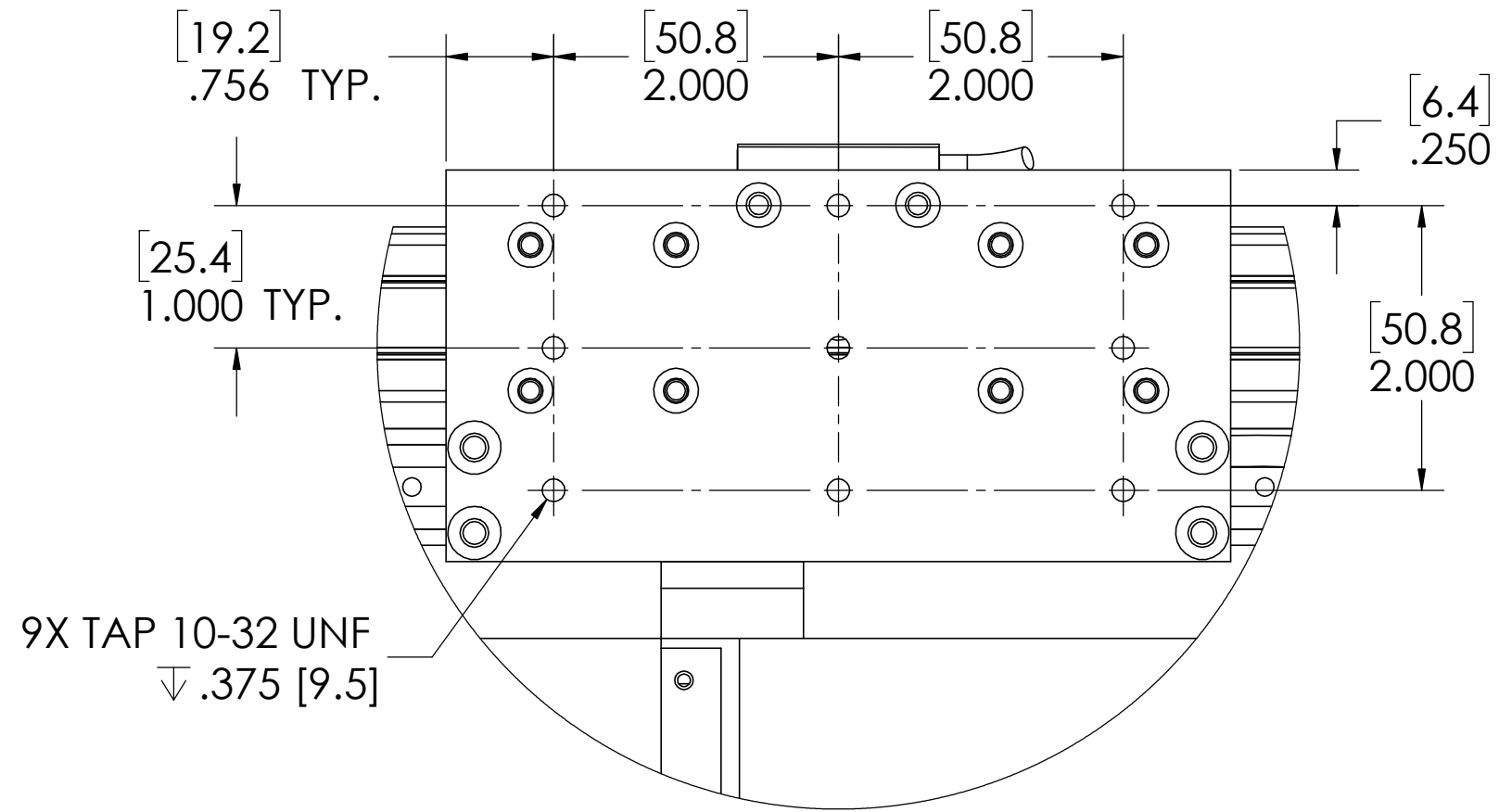
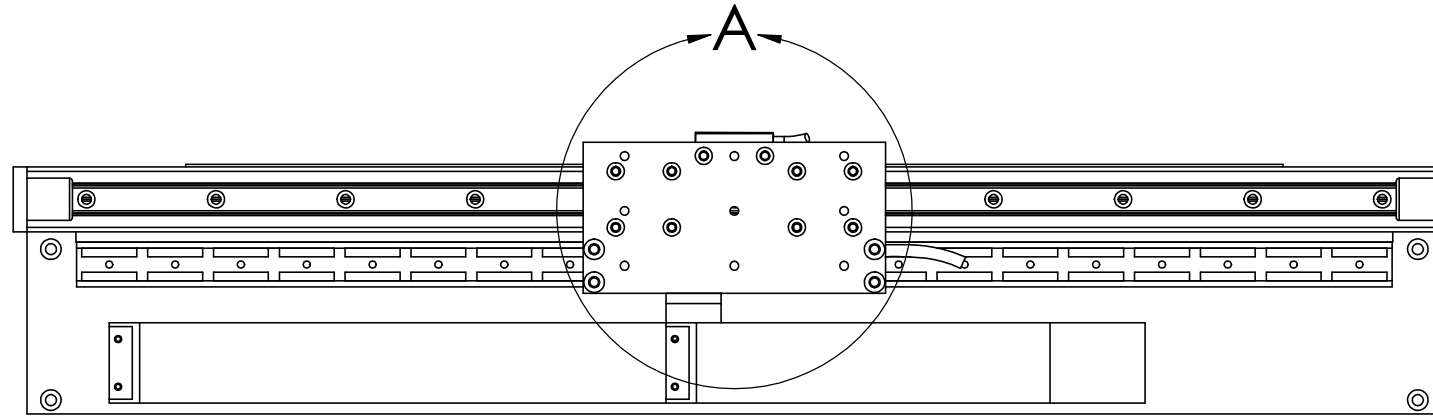

DETAIL A  
SCALE 1 : 1.25



**H2W Technologies, Inc.**  
 Santa Clarita, CA 91350 USA  
 Tel: (661) 291-1620  
[www.h2wtech.com](http://www.h2wtech.com)

These drawings and specifications are the property of H2W Technologies, Inc. They are issued in confidence and shall not be reproduced, copied, or used without written permission from H2W Technologies, Inc.

UNLESS SPECIFIED OTHERWISE:  
 All dimensions are in inches  
 Standard Tolerances are as follows  
 .XXX ±.005 ANGLES ±.1°  
 .XX ±.010 FILLETS .010  
 .X ±.020 CORNERS .010  
 Remove All Burrs and Sharp Edges

**FOR  
 REFERENCE  
 ONLY**

MATERIAL

FINISH

TITLE

Single Rail Positioning Stage Model #:  
**SRS-018-05-013-01-EX**

DWG #

**40-0354**

REV

----

DATE  
 3-15-17

SHEET  
 2 of 3

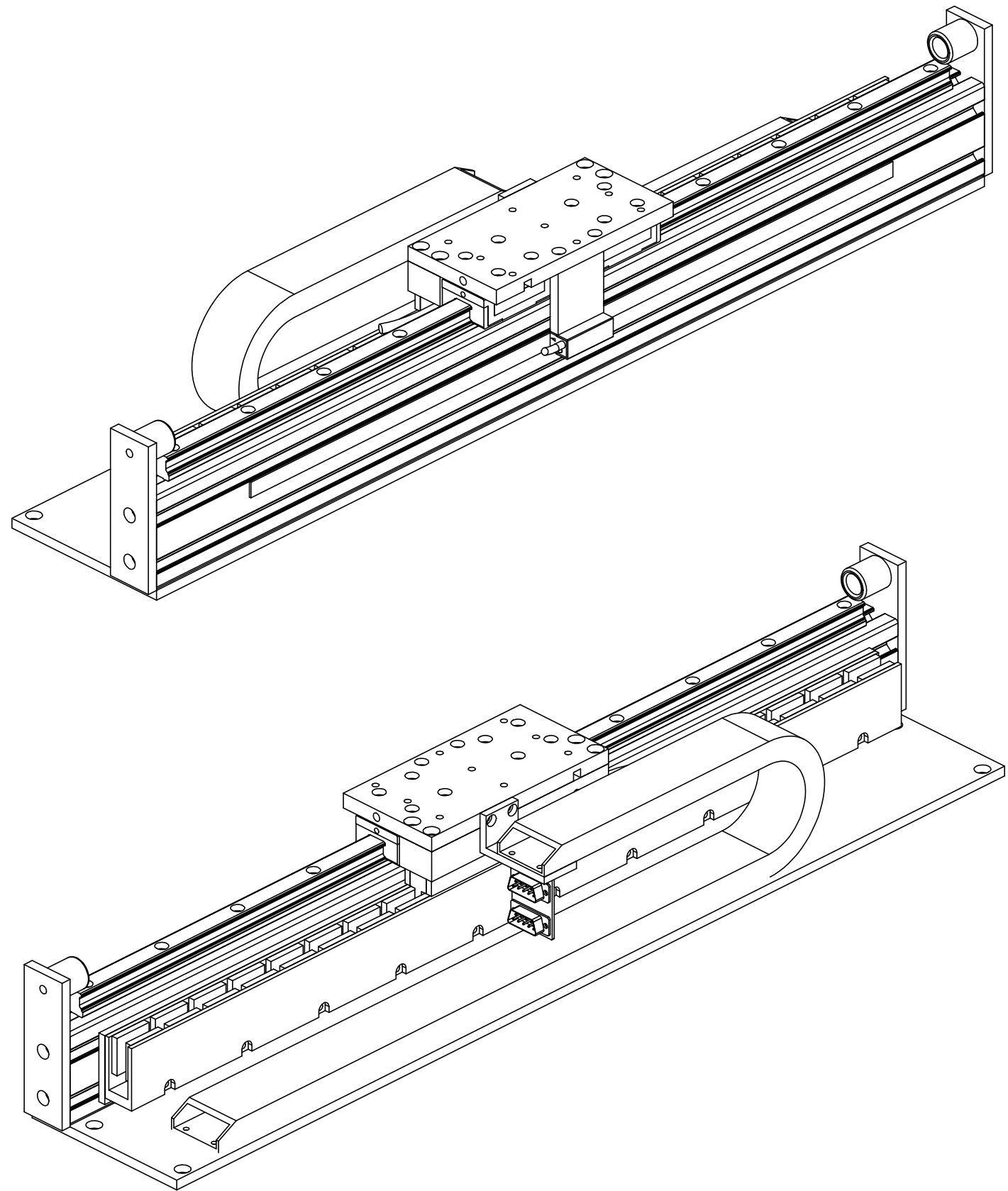

SINGLE RAIL POSITIONING STAGE SPECIFICATIONS		
Motor P/N	BLDM-B04	
Stroke	18.6 in	472.4 mm
Encoder Resolution	1 micron	
Bearing Type	Recirculating Ball	
Moving Mass	2.75 lbs	1.25 kg
Total Mass	18.0 lbs	8.1 kg
Resistance @ 20C	6.4 ohms	
Inductance @ 20C	4.0 mH	
Electrical Time Constant	1.0 msec	
Motor Constant	1.17 LBS/SQRT(Watt)	5.2 N/SQRT(Watt)
Force Constant	3.0 LBS/Amp	13.2 N/Amp
Back EMF	0.34 V/ips	13.2 V/m/sec
Force @ 100% Duty	6.2 lbs	27.8 N
Power @ 100% Duty	39.3 watts	
Current @ 100% Duty	2.1 amps	
Force @ 10% Duty	18.7 lbs	83.3 N
Power @ 10% Duty	353.7 watts	
Current @ 10% Duty	6.3 amps	
Stage Length	26.28 in	667.7 mm
Stage Width	5.12 in	130.3 mm
Stage Height	3.92 in	99.5