

1

2

3

4

5

REVISION TABLE

REV	ECN#	DESCRIPTION	REV BY	APPROVED	DATE
---	---	Original Drawing	SDC	MPW	7-8-15

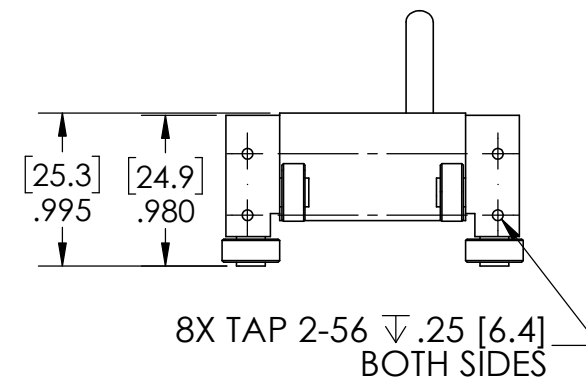
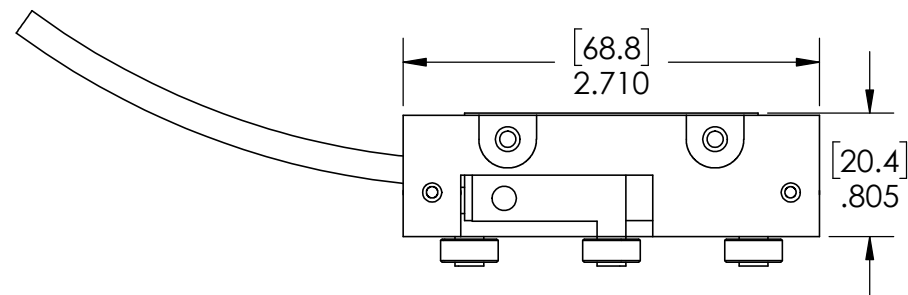
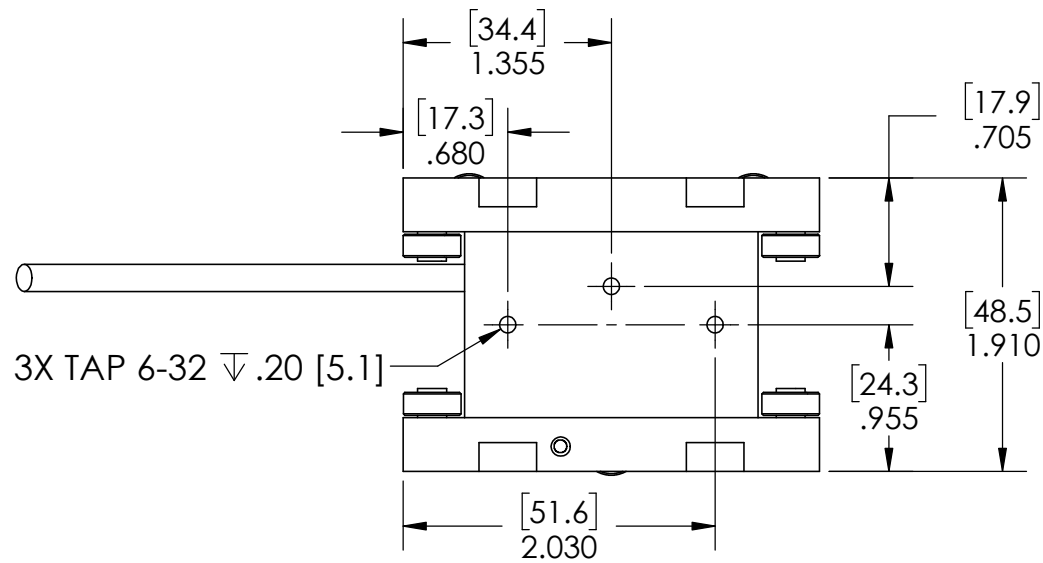

H2W Technologies, Inc.
Santa Clarita, CA 91350 USA
Tel: (661) 291-1620
www.h2wtech.com

These drawings and specifications are the property of H2W Technologies, Inc. They are issued in confidence and shall not be reproduced, copied, or used without written permission from H2W Technologies, Inc.

UNLESS SPECIFIED OTHERWISE:
All dimensions are in inches
Standard Tolerances are as follows
.XXX ±.005 ANGLES ±.1°
.XX ±.010 FILLETS .010
.X ±.020 CORNERS .010
Remove All Burrs and Sharp Edges

**FOR
REFERENCE
ONLY**

MATERIAL

FINISH

TITLE

Single Axis Stepper Model #:
LMSS0602-2WWO

DWG # **10-0610**

REV ----

DATE 7-8-15 SHEET 1 of 4

1

2

3

4

5

COMPATIBLE PLATEN SPECIFICATIONS

A

A

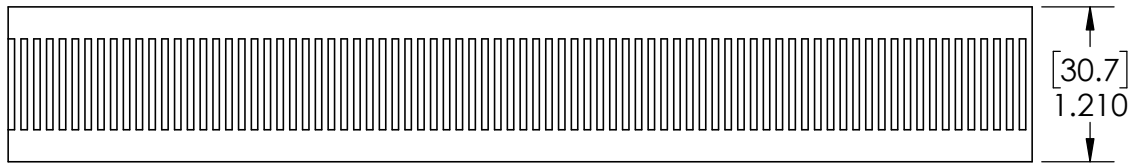

B

B

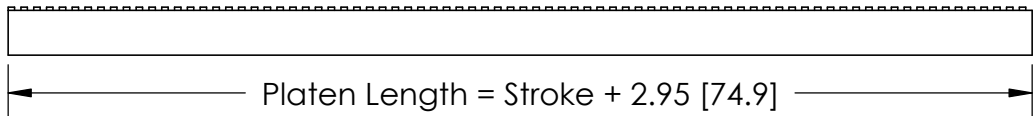
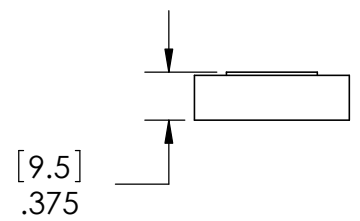

C

C

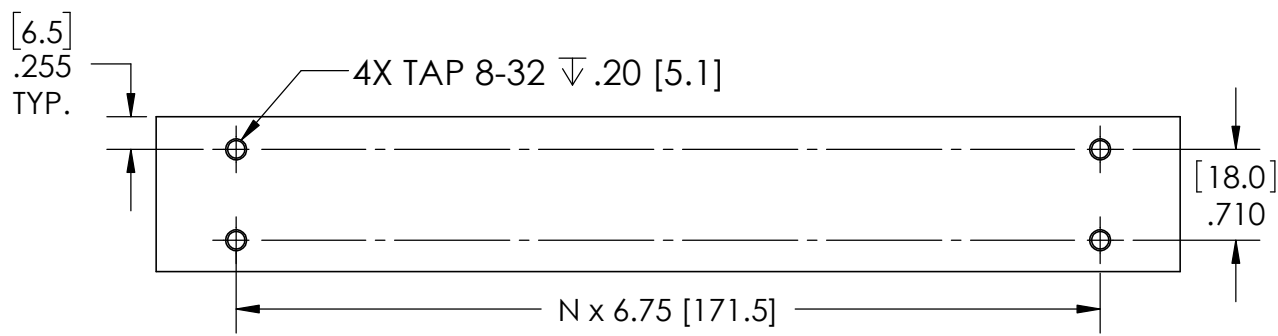

D

D

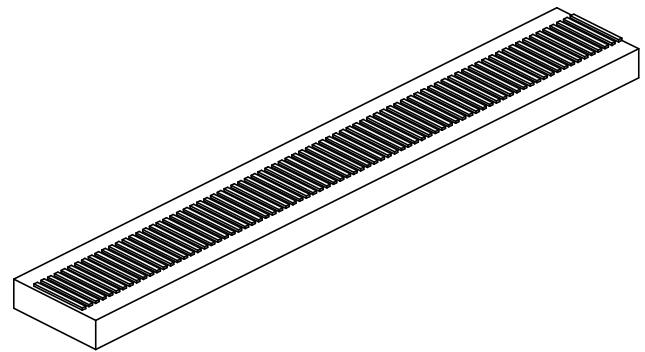

Platen Model #: STP-13-XXX-R

1

2

3

4

5

MOTOR SHOWN MOUNTED ON PLATEN

A

A

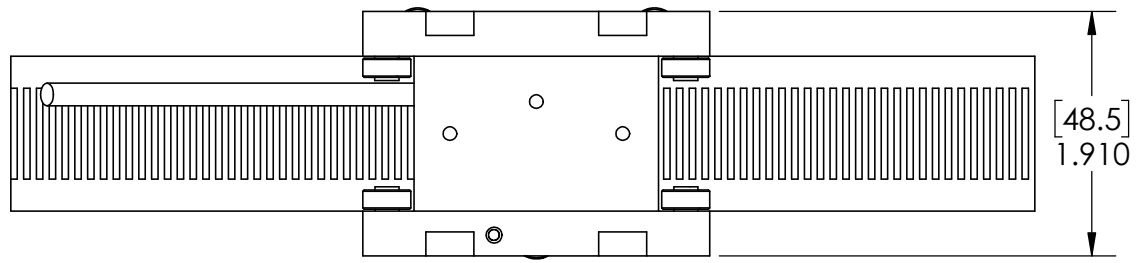

B

B

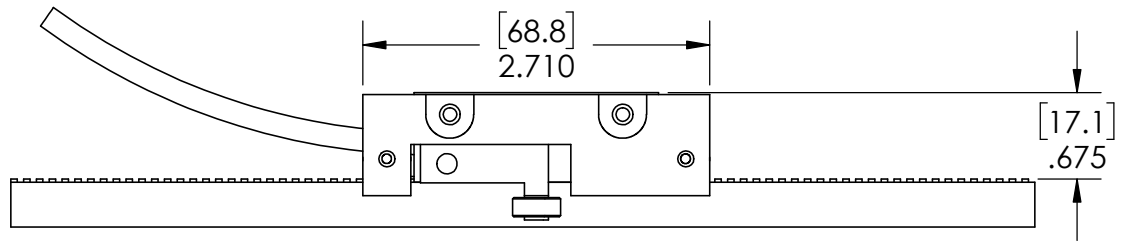
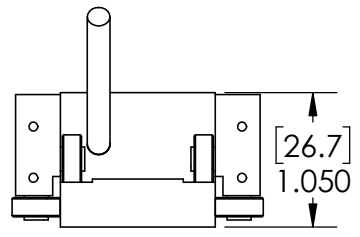

C

C

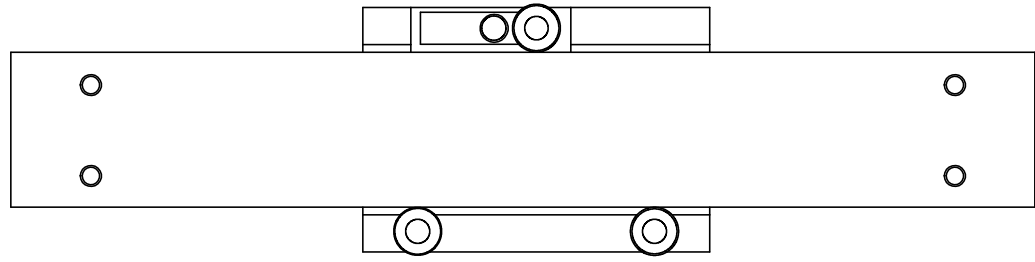
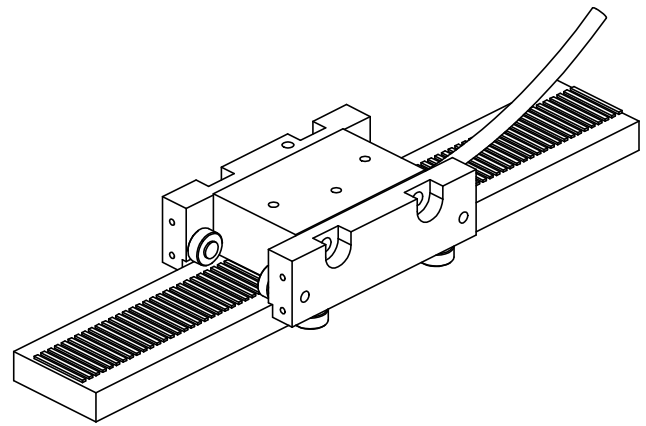

D

D



H2W Technologies, Inc.
 Santa Clarita, CA 91350 USA
 Tel: (661) 291-1620
www.h2wtech.com

These drawings and specifications are the property of H2W Technologies, Inc. They are issued in confidence and shall not be reproduced, copied, or used without written permission from H2W Technologies, Inc.

UNLESS SPECIFIED OTHERWISE:
 All dimensions are in inches
 Standard Tolerances are as follows
 .XXX ±.005 ANGLES ±.1°
 .XX ±.010 FILLETS .010
 .X ±.020 CORNERS .010
 Remove All Burrs and Sharp Edges

FOR REFERENCE ONLY

MATERIAL
 FINISH

TITLE
 Single Axis Stepper Model #:
LMSS0602-2WWO

DWG # **10-0610**
 REV ----
 DATE 7-8-15 SHEET 3 of 4

1

2

3

4

5

LINEAR STEPPER MOTOR SPECIFICATIONS

Motor P/N	LMSS0602-2WW0	
Continuous Force	2.0 LBS	8.9 N
Rated Current	1.5 Amp	
Resistance/Phase @ 20C	1.5 ohms	
Inductance/Phase @ 20C	1.2 mH	
Motor Phases	2	
Bearing Type	Roller Bearing	
Nominal Airgap	0.0015"	
Motor Mass	6.4 oz	181 grams

MOTOR POWER CABLE

Lead Color	Function
Yellow	A+
White	A-
Red	B+
Black	B-

LEAD WIRE LENGTH: 10in [254mm]

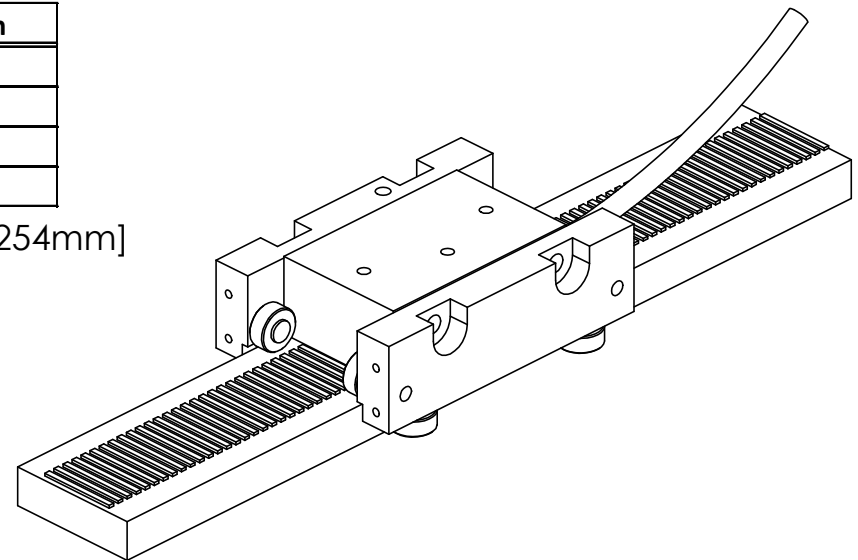
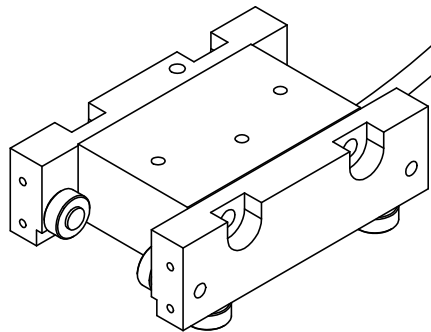

H2W Technologies, Inc.

Santa Clarita, CA 91350 USA
Tel: (661) 291-1620

www.h2wtech.com

These drawings and specifications are the property of H2W Technologies, Inc. They are issued in confidence and shall not be reproduced, copied, or used without written permission from H2W Technologies, Inc.

UNLESS SPECIFIED OTHERWISE:
All dimensions are in inches
Standard Tolerances are as follows
.XXX ±.005 ANGLES ±.1°
.XX ±.010 FILLETS .010
.X ±.020 CORNERS .010
Remove All Burrs and Sharp Edges

**FOR
REFERENCE
ONLY**

MATERIAL

FINISH

TITLE

Single Axis Stepper Model #:

LMSS0602-2WW0

DWG #

10-0610

REV

DATE

7-8-15

SHEET

4 of 4