

1

2

3

4

5

REVISION TABLE					
REV	ECN#	DESCRIPTION	REV BY	APPROVED	DATE
---	---	Original Drawing	SDC	MPW	5-12-15

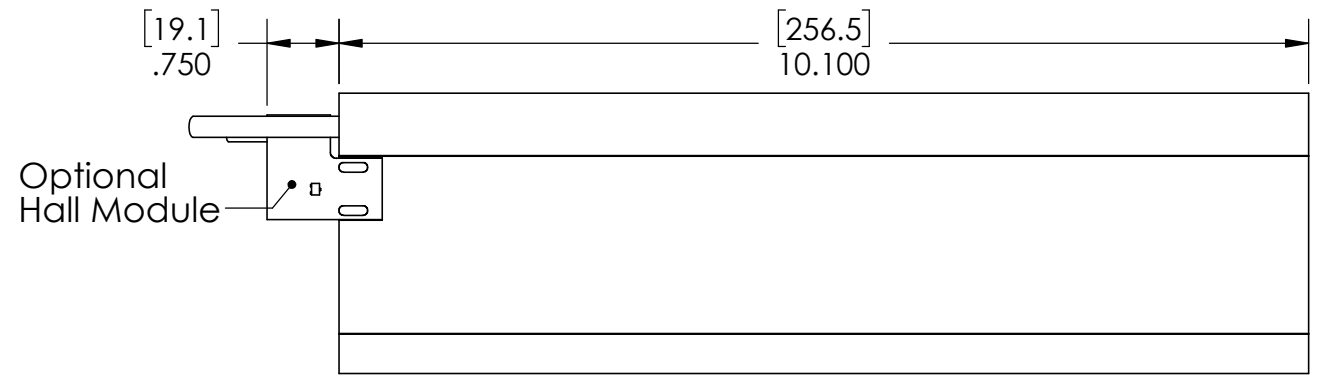
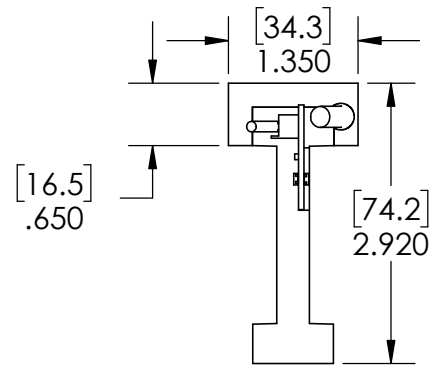
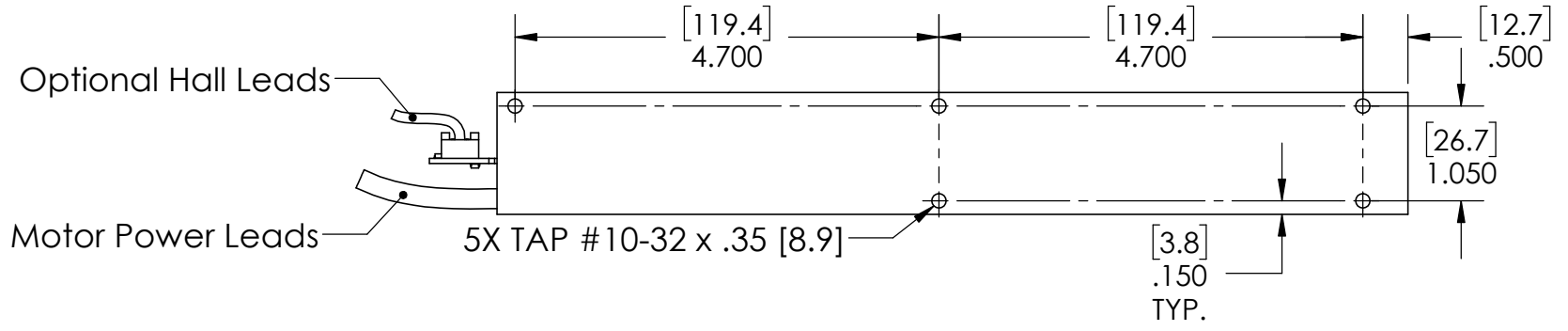

Standard Cable Length = 1 meter

1

2

3

4

5

A

A

OPTIONAL HALL MODULE MUST BE IN  
MAGNET TRACK FOR COMMUTATION

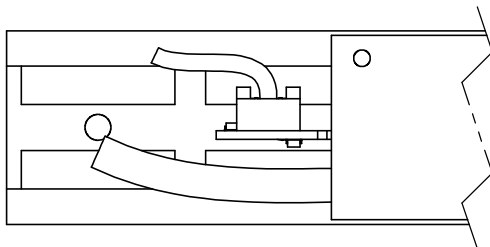

B

B

MOTOR COIL SHOWN  
WITH MAGNET TRACK

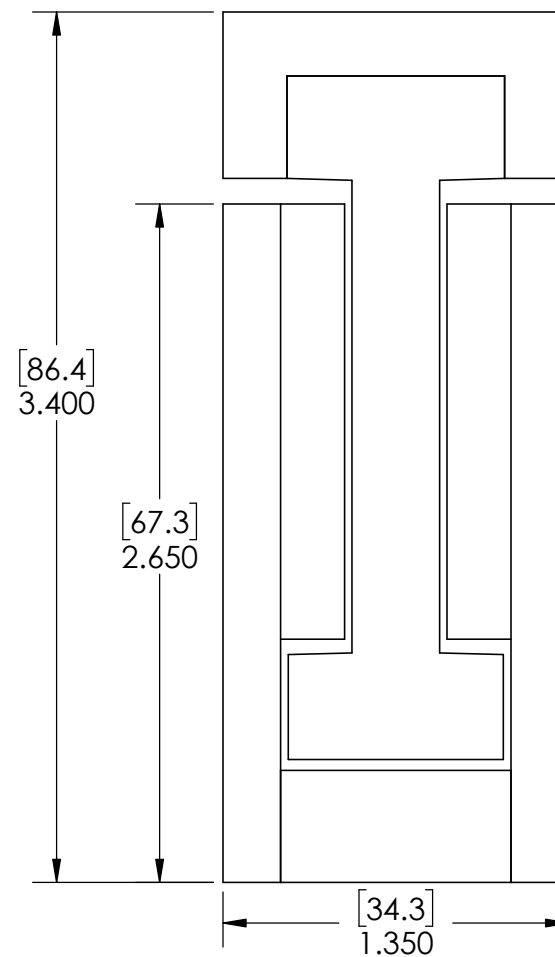

C

C

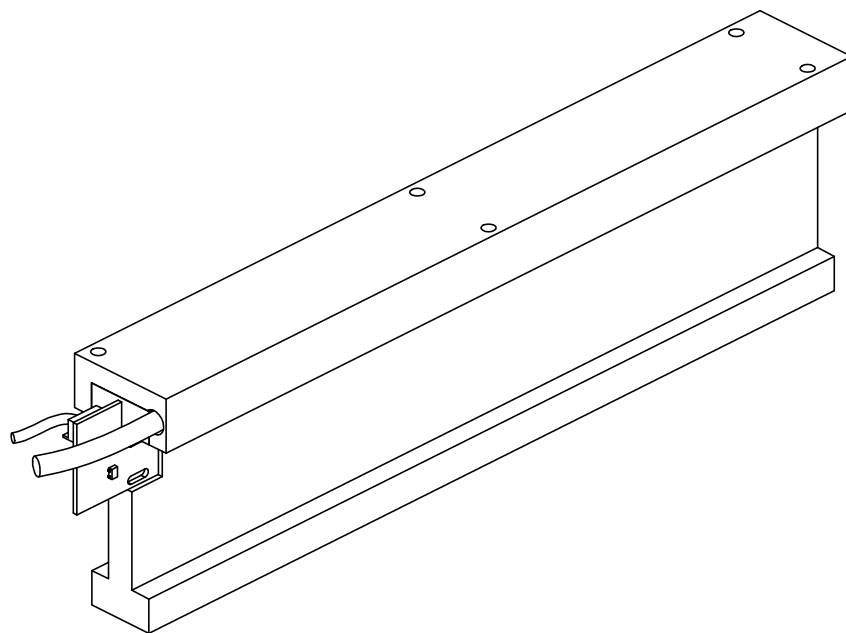

D

D



**H2W Technologies, Inc.**

Santa Clarita, CA 91350 USA  
Tel: (661) 291-1620

[www.h2wtech.com](http://www.h2wtech.com)

These drawings and specifications are the property of H2W Technologies, Inc. They are issued in confidence and shall not be reproduced, copied, or used without written permission from H2W Technologies, Inc.

UNLESS SPECIFIED OTHERWISE:  
All dimensions are in inches  
Standard Tolerances are as follows  
.XXX ±.005 ANGLES ±.1°  
.XX ±.010 FILLETS .010  
.X ±.020 CORNERS .010  
Remove All Burrs and Sharp Edges

**FOR  
REFERENCE  
ONLY**

MATERIAL

FINISH

TITLE

Ironless Motor Coil Model #:

**BLDM-D08**

DWG #

**20-0222**

REV

----

DATE

5-12-15

SHEET

2 of 3

1

2

3

4

5

A

A

Motor Specifications		
BLDM-D08		
General		
Continuous Force	lbs [N]	33 [147]
Continuous Current	Amps	1.5
Continuous Power	Watts	103.5
Peak Force @ 10% Duty	lbs [N]	99 [441]
Peak Current @ 10% Duty	Amps	4.4
Peak Power @ 10% Duty	Watts	931.5
Electrical		
Force Constant	lbs/Amp [N/Amp]	22.3 [99.3]
Back EMF	V/in/sec [V/m/sec]	2.52 [99.3]
Resistance	Ohms	36.4
Inductance	mH	48.3
Electrical Time Constant	msec	1.3
Km Motor Constant	lbs/sqW [N/sqW]	3.7 [16.4]
Mechanical		
Electrical Cycle Length	in [mm]	2.4 [60.96]
Number of Poles	8	
Coil Assembly Length		
with Hall Sensor	in [mm]	10.85 [275.6]
without Hall Sensor	in [mm]	10.1 [257]
Coil Assembly Weight	lbs [kg]	2.6 [1.2]
Magnet Track Weight	lbs/in [kg/m]	0.65 [11.63]

B

B

Wiring	
Motor	
Phase A	White/Red Stripe
Phase B	White
Phase C	White/Black Stripe
Ground	White/Green Stripe
Thermostat 1	Blue
Thermostat 2	Orange
Hall Effect	
Hall A	White
Hall B	Red
Hall C	Black
Hall Ground	Green
Hall Power (+5-24VDC)	Brown, Orange, Violet, Yellow

C

C

D

D

**H2W Technologies, Inc.**

 Santa Clarita, CA 91350 USA  
 Tel: (661) 291-1620

[www.h2wtech.com](http://www.h2wtech.com)

These drawings and specifications are the property of H2W Technologies, Inc. They are issued in confidence and shall not be reproduced, copied, or used without written permission from H2W Technologies, Inc.

 UNLESS SPECIFIED OTHERWISE:  
 All dimensions are in inches  
 Standard Tolerances are as follows  
 .XXX ±.005 ANGLES ±.1°  
 .XX ±.010 FILLETS .010  
 .X ±.020 CORNERS .010  
 Remove All Burrs and Sharp Edges

**FOR  
REFERENCE  
ONLY**

MATERIAL

FINISH

TITLE

Ironless Motor Coil Model #:

**BLDM-D08**

 DWG # **20-0222**

REV

----

DATE

5-12-15

SHEET

3 of 3